

**THERMINOL®**  
from Eastman

EASTMAN HEAT TRANSFER FLUIDS

# Liquid-phase system design guide

A design, operating and maintenance guide for  
low-cost, low-pressure heat transfer systems



# Content

|   |           |
|---|-----------|
| <b>Introduction</b> .....   | <b>1</b>  |
| Applications of liquid-phase Therminol heat transfer fluids .....                           | 1         |
| Advantages of liquid-phase Therminol heat transfer fluids .....                             | 1         |
| Therminol heat transfer fluid versus steam .....  | 1         |
| Therminol heat transfer fluid versus direct-fired heating .....                             | 2         |
| Total Lifecycle Care™ program .....   | 2         |
| Therminol technical literature .....  | 2         |
| <b>Process design factors</b> .....   | <b>3</b>  |
| Advantages of proper design .....   | 3         |
| System factors .....  | 3         |
| Fluid factors .....   | 4         |
| Fluid sampling .....  | 4         |
| <b>Mechanical design factors</b> .....  | <b>5</b>  |
| The heater .....  | 5         |
| Effect of liquid velocity on film temperature during heating .....                          | 5         |
| Heat transfer coefficients .....  | 6         |
| Pumps .....   | 6         |
| Filters .....   | 6         |
| Materials of construction .....   | 6         |
| Expansion tank and venting arrangements .....   | 7         |
| Pipework .....  | 7         |
| Expansion tank and cold seal trap .....   | 8         |
| Insulation .....  | 9         |
| Valves .....  | 9         |
| Packing .....   | 9         |
| Controls .....  | 9         |
| Fire protection .....   | 9         |
| Safety controls .....   | 10        |
| <b>Typical liquid-phase heat systems</b> .....  | <b>11</b> |
| System 1 — The basic system .....   | 11        |
| System 2 — Heating multiple users .....   | 12        |
| System 3 — Heating several users at different temperatures .....                            | 13        |
| System 4 — Heating and cooling of a single user .....                                       | 14        |
| <b>Start-up</b> .....   | <b>15</b> |
| Suggested start-up procedure for new systems .....  | 15        |
| <b>Operating instructions</b> .....   | <b>16</b> |
| Suggested operating instructions for liquid-phase heating systems using Therminol fluids .. | 16        |
| Safe handling and disposal .....  | 17        |
| <b>Resistance of valves and fittings</b> .....  | <b>18</b> |
| <b>Steel pipe dimensions</b> .....  | <b>19</b> |
| <b>Engineering conversion factors</b> .....   | <b>20</b> |
| <b>Average properties of tubes</b> .....  | <b>21</b> |

# Introduction

## THERMINOL<sup>®</sup> from Eastman

The Eastman Therminol heat transfer fluids team has more than 60 years of experience designing, producing and marketing synthetic heat transfer fluids. Therminol heat transfer fluids by Eastman have been developed for a range of applications — from chemical and petroleum processing to solar energy. Eastman markets an extensive line of Therminol heat transfer fluids to match the unique requirements of the many applications and technologies using heat transfer fluids. No single fluid has the best properties for all applications. **Therminol fluids are available for a wide operating range, from a high temperature of 400°C (750°F) to a low temperature of -115°C (-175°F).**

There are two general types of heat transfer fluid systems: liquid-phase and vapor/liquid-phase. Liquid-phase systems operate via transfer of sensible heat (a change in temperature). Vapor/liquid systems transfer heat with the heat of vaporization via a boiling condensing cycle. Eastman produces and markets both fluid types in the Therminol line. This guide will assist in the design, operation and maintenance of liquid-phase heat transfer systems utilizing Therminol fluid. Information on vapor/liquid-phase heat transfer fluids is available through your local Therminol specialist.

[Therminol.com](http://Therminol.com)

## Applications of liquid-phase Therminol heat transfer fluids

Virtually any process or manufacturing operation requiring heat transfer between 400°C (750°F) and -115°C (-175°F) is a candidate for the application of Therminol heat transfer fluids. Applications that involve any of the following requirements are particularly well suited for the use of liquid-phase heat transfer fluid:

- Carefully controlled high-temperature heating
- Multiple heat users within a single process or plant
- Heating of thermally sensitive materials
- Heating and cooling with the same system
- Cooling
- Operation where minimal operating supervision is available

## Advantages of liquid-phase Therminol heat transfer fluids

### *Therminol heat transfer fluids versus steam*

Compared to steam, Therminol heat transfer fluids cost less to install, operate and maintain. Low-pressure thermal liquid systems using Therminol fluids can significantly reduce capital costs. The savings in eliminating installation of larger-diameter vapor piping, special vent piping, flash drums, pressure control devices and boiler feedwater treatment equipment can amount to 25%–50% of the system cost.

A second source of savings is in operation: thermal liquid systems require less maintenance, eliminate heat lost through draining of steam condensate in supply lines, and do not usually require licensed operating personnel when operated in a manner consistent with the recommendations in this guide (however, check local codes).

Therminol fluids have minimal potential for corrosion and fouling. Cost of chemical treatment of boiler feedwater is eliminated, as well as the environmental cost of boiler blowdown water disposal.

## Therminol heat transfer fluid versus direct-fired heating

Heat transfer systems utilizing Therminol heat transfer fluid eliminate the problems associated with direct-fired heating. Heat transfer fluid systems eliminate hot spots that can overheat sensitive process material while providing close and accurate process temperature control. Heat transfer fluid systems also allow the major source of ignition (the heater) to be installed remotely from the process, reducing fire hazards and improving plant safety. With heat transfer fluid systems using Therminol fluids, one heater can provide heat to any number of users.

In summary, heat transfer fluid systems using liquid-phase Therminol heat transfer fluids offer the designer and the operator the following advantages:

- Simple to design
- Easy to operate
- Low maintenance cost
- Minimal capital cost
- Energy efficient
- Eliminates multiple ignition sources
- Flexible operation (heats and cools)

## Total Lifecycle Care program

Total Lifecycle Care is a comprehensive service that uses analytics, sampling and training to prevent heat transfer system failures, ensuring safe, efficient and uninterrupted operations.

- Offers industry-leading technical support
- Provides data through Fluid Genius™ for informed decision-making
- Helps minimize unexpected downtime and maintenance costs
- Assists in maximizing fluid life
- Enables safe working environments through tailored safety training
- Helps keep systems running smoothly

For further information about selection of products or evaluation of application, contact your Eastman Therminol heat transfer fluid specialist.

**Our technical assistance toll-free number is 800-433-6997.**

## Therminol technical literature

Eastman offers a complete library of technical literature, including technical data sheets, Safety Data Sheets, system design data and more. Much of the information is also accessible through [therminol.com](http://therminol.com).

# Process design factors

## Advantages of proper design

Every thermal fluid system is different. Operating temperatures, flow rates, process equipment, system components and a host of other design details vary from system to system. But one thing remains constant: Properly designed and operated heat transfer fluid systems are exceptionally reliable and economical.

Well-designed systems are safer, start up faster, deliver better on-stream time, use less energy and require less fluid.

The temperature requirements of a particular system are especially important in selecting the proper Therminol fluid. For a particular system are the temperature requirements of its operation. In any range, the fluids are suited for systems that must deliver uniform heat, precise temperature control and quick response to heating or cooling demand.

While there is nothing profoundly different or highly complicated about a system using Therminol fluid, certain design parameters must be observed for the system to give good service life, to operate efficiently and to return all the benefits of heating or cooling with a nonpressurized liquid.

There are five basic engineering checkpoints of designing a system:

1. **The heater**—to control heat transfer rate to ensure consistent energy supply with minimal fluid degradation
2. **The pumps and piping**—to provide adequate system circulation, maintain the heat flux at user stations and ensure proper handling of the fluid
3. **The expansion tank**—to provide for fluid expansion, venting and positive pump suction head. A properly designed expansion tank reduces difficulties in start-up and contributes to trouble-free system operation.
4. **The process/safety controls**—to ensure safe operation and effective use of the heating/cooling system
5. **The materials and construction**—to ensure compatibility, proper layout and design

With sufficient heater capacity, good control of flow at user stations and compatible materials, a well-designed system can provide reliable, efficient and precise heat delivery. Proper selection of fluid and a clean, moisture-free system allow minimum maintenance and trouble-free operation.

## System factors

Liquid heat transfer is basically heating or cooling an adequate quantity of fluid to a practical working temperature and circulating it to user stations at a rate to control the temperature of the user as required by the process. Thus, in designing a system, the following requirements should be considered:

- Is the process a continuous or batch operation?
- What is the energy demand and the temperature requirement of each energy user? The cooling requirement?
- How much heat transfer area will be practical or available at user stations, and what heat transfer coefficient can be expected from the heat transfer fluid and the material being processed at the user heat exchange surfaces?
- Will more than one energy user be on stream at the same time? At the same temperature? At different temperatures?
- What heat losses will be expected in the physical layout of the system? What is the pressure drop?
- Can older equipment or less-efficient heating systems be eliminated?
- Are expanded heating requirements probable?
- To what ambient conditions will the system be exposed?
- Are personnel/property/environmental protection controls adequate?

A basic starting point is to estimate the energy balances and determine the total energy demand of the system. This will guide selection of the heater capacity and pump size, determine the fluid operating temperatures and indicate the type of Therminol fluid the system will require.

## Fluid factors

Therminol heat transfer fluids are chemically and thermally stable liquids. To achieve optimum fluid life, users should observe the recommended bulk and film temperature limits for each fluid. These limits are specified for each Therminol fluid on the individual product data sheet. When not subjected to contamination, i.e., moisture, air, process materials, etc., or heat stress beyond their limits, Therminol fluids can give years of service without significant physical or chemical change.

Liquid-phase Therminol fluids transfer heat by sensible mode rather than latent mode as with condensing vapor. Heated liquid, circulated at reasonable velocities over a heat-using surface, can be a more efficient and more readily controlled method of heat transfer than pressure- or temperature-controlled condensing vapor systems.

Therminol heat transfer fluids are designed to have physical properties that enhance their value in liquid-phase heat transfer. Low vapor pressure and high boiling ranges permit operation at their maximum recommended temperatures without the need to pressurize the system. The particular chemical compounds in Therminol fluids have always been recognized as among the most thermally stable.

All heat transfer fluids have a time-temperature decomposition relationship. Decomposition of heat transfer fluid results in the formation of components that are both lower boiling and higher boiling than new fluid. Low boilers should be periodically vented from the system to a safe area (usually through a manual vent) from a hot operating expansion tank (see page 9). Therminol fluids are designed to produce ventable low boilers in the event of decomposition. High boilers are soluble in the fluid up to a certain level, and before this level is reached, the fluid charge should be replaced. The old fluid should be disposed in an approved manner.

As with any heat transfer fluid, the design of the system must consider the relationship between thermal energy from the source and the thermal properties of the fluid, fluid velocity and heat transfer surface geometry. The liquid film in immediate contact with the heat source surface (whether electric or fuel fired) is subjected to higher temperatures than the bulk temperature of the fluid stream. Minimum film thicknesses are achieved in fully developed turbulent flow.

The velocity and the associated turbulence of the circulating fluid, therefore, is a critical determinant of how much fluid is subjected to the higher temperatures and for how long. The differential between the fluid bulk temperature and the film temperature depends on the fluid velocity over the surface of the heat source and the physical properties of the fluid used. The maximum recommended bulk fluid use temperature and film temperature are given in each Therminol product bulletin. Therminol fluids have high specific heat, high thermal conductivity, high density and low viscosity, which make them efficient heat carriers.

In selecting both the heater and the fluid, the maximum fluid temperature — rather than the average — should be considered and a reasonable safety margin allowed to enable the fluid to give the longest practical service life. Therminol synthetic heat transfer fluids are formulated to provide a strong and efficient link for both heating and cooling demands.

Therminol fluids are available for use in a series of temperature ranges, with fluids capable of operating as low as  $-115^{\circ}\text{C}$  ( $-175^{\circ}\text{F}$ ) and up to  $400^{\circ}\text{C}$  ( $750^{\circ}\text{F}$ ).

## Fluid sampling

When operating Therminol fluids near their upper temperature limit, the system should be monitored yearly for fluid quality to determine whether corrective actions are required. When operating at temperatures  $20^{\circ}\text{C}$  ( $50^{\circ}\text{F}$ ) or more below the upper operating limit, routine samples should be analyzed biannually. Fluid samples should be analyzed whenever fluid-related system problems are suspected. Eastman will perform free sample analysis and indicate necessary corrective action required should results be outside acceptable values for the fluid.

Special heat transfer fluid sampling kits can be requested through your Therminol fluid specialist by calling 800-433-6997 or through [therminol.com](http://therminol.com).

**Note:** *Most fluid samples should be taken from a flowing line and cooled below  $93^{\circ}\text{C}$  ( $200^{\circ}\text{F}$ ) before placing in a clean sample container (cooling fluids may require lower sampling temperatures).*

# Mechanical design factors

## The heater

The heater, either electrical or fuel fired, is a critical component in designing a heat transfer system with Therminol fluid. With the proper balance of heating capacity, temperatures and fluid velocity, the service life of the heat transfer fluid is increased to the maximum. Again, good service life is achieved only in systems protected from contamination with foreign material.

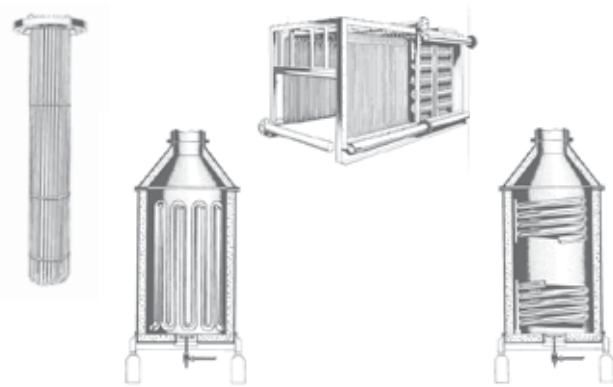

Two basic fired heater designs for Therminol heat transfer fluids are available: the liquid tube and fire tube types. In liquid tube heaters, Therminol fluid is pumped through the tubes as it is heated. The fire is outside the tubes. In fire tube heaters, Therminol fluid flows through the heater "shell" around the outside of the fire tubes. Liquid tube heaters are preferred at all temperatures. At temperatures below 260°C (500°F), fire tube heaters with a special baffle design can be used to eliminate hot spots.

Most Therminol fluids are liquid when transferring heat. To avoid hot spots in the heater, the fluid should be pumped over the heating surfaces at sufficient velocity so that no area of fluid stagnation occurs. Since heating is not uniform in fired heaters, the maximum heat stress conditions must be used to determine what film temperatures will be encountered.

Fluid velocities over the heat transfer surfaces must be relatively high to develop turbulent flow. This helps avoid excessive film temperatures that may be detrimental to heat transfer surfaces and to the fluid. The heater manufacturer should be consulted for the required flow velocities.

## Effect of liquid velocity on film temperature during heating

The following illustration shows the effect of fluid velocity on film temperature and indicates the importance of this heater design requirement.

In electrical heaters, all the heat delivered by the elements passes into the fluid. The maximum heat flux at the surface of the heat source and the fluid velocity over it should be in proper balance to avoid excessive film temperature. As with fired heaters, careful attention must be paid to achieving turbulent flow (without stagnation zones) around the heat transfer surfaces to eliminate hot spots and localized fluid boiling.

In general, Therminol heat transfer fluids can give long service life if the maximum bulk and the maximum film temperatures of the system do not exceed the recommended maximum limits for the particular fluid and if no contamination or exposure to oxygen occurs.

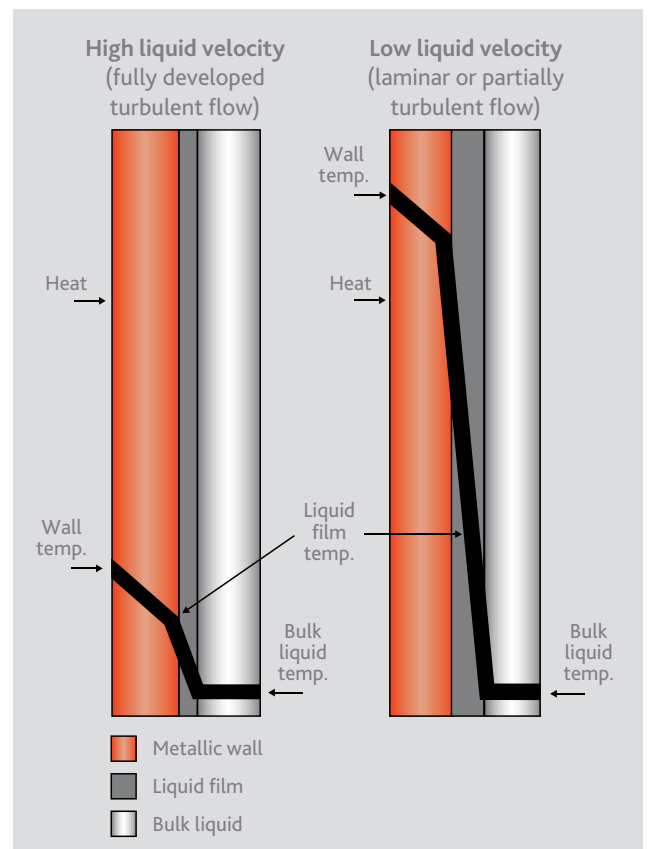

## Heat transfer coefficients

To determine overall heat transfer coefficients for the heating system, individual coefficients have to be calculated for the heat source side and the fluid service side at each user station. For fully developed turbulent flow through a circular tube with a constant wall temperature, the average film coefficients for Therminol fluids can be estimated by using a Sieder-Tate\* type equation:

$$\frac{hD}{k} = 0.022 \left[ \frac{DG}{\mu} \right]_b^{0.8} \left[ \frac{C_p \mu}{k} \right]_b^{0.4} \left[ \frac{\mu_b}{\mu_w} \right]^{0.16}$$

$$\frac{DG}{\mu} = \text{Reynolds number (dimensionless)} \quad \frac{hD}{k} = \text{Nusselt number (dimensionless)}$$

$$\frac{C_p \mu}{k} = \text{Prandtl number (dimensionless)} \quad \frac{\mu_b}{\mu_w} = \text{Viscosity correction factor}$$

### In this equation:

$h$  = Film heat transfer coefficient  
 $D$  = Internal pipe diameter or hydraulic diameter  
 $k$  = Fluid thermal conductivity at bulk temperature "b"  
 $G$  = Mass velocity  
 $C_p$  = Fluid specific heat at bulk temperature "b"  
 $\mu$  = Fluid absolute viscosity  
 $\mu_b$  = Fluid viscosity at bulk temperature "b"  
 $\mu_w$  = Fluid viscosity at wall (film) temperature "w"

## Pumps

Pumps must have sufficient capacity and pressure head to circulate the fluid at the rate required by the particular installation. For large flow rates, the pump should generally be of the centrifugal type. Pumps conforming to ANSI B73.1 or to API Standard 610, for high-temperature service, will usually be suitable. Fluid-cooled bearings and seals are recommended to extend pump service life.

For most systems, cast steel pumps are preferred. Pump manufacturers usually specify that above 230°C (450°F) a cooled, jacketed stuffing box or a cooled mechanical seal should be used. Mechanical seals are widely used. Secondary sealing with vent and drain glands is recommended to collect fluid leakage and to provide space for inerting the outside of the seal. Inert blanketing of the seal with steam or nitrogen eliminates oxidation deposit formation, which can lead to seal leakage. This secondary sealing provides additional safety in the case of sudden seal failure.

\*A modification of the Sieder-Tate equation for all liquids except water

Sealless pumps (magnetically driven and canned motor) are regularly employed in Therminol fluid systems. Because of the operating temperatures and range of viscosities often encountered in Therminol fluid systems, the pump manufacturer should be consulted.

On pumps with a stuffing box, at least five rings of packing should be provided (i.e., laminar graphite rings). When a new system is first put into operation, a slight leakage may be noticed at the pump packing. The pump gland should not be tightened, however, until the system has heated to near the temperature of operation.

Regardless of the type of pump selected, the flow rate should be checked regularly against the pump's performance when new. To prevent alignment problems and seal leakage, it is important to avoid pipe support stresses on the body of the pump. Each pump should be fitted with a control device to switch off the heat source in case of pump failure.

If expansion loops are used in the pump suction piping, they should be installed horizontally.

## Filters

Before starting up a new system, install a wire mesh strainer in the pump section. These strainer baskets may be removed after debris removal from start-up is completed.

Piping systems should be designed with provisions for the installation of a side-stream filter.

Filters that have generally been employed for these applications are glass-fiber string-wound cartridges or cleanable sintered metal filters in the 1–30 micron range.

Clean fluids prolong the life of system components, (i.e., pump shaft seals and valve stems). Filtration also reduces fouling and plugging.

## Materials of construction (excluding heater coils)

Process chemistry is normally used to determine materials of construction. The majority of metals and alloys normally encountered in high-temperature heating systems can be used with Therminol heat transfer fluids.

Materials of construction are generally selected on the basis of their suitability for operation throughout the system's temperature range.

Mild steel is widely used, but it must be qualified for low-temperature use (brittle/ductile transition temperature).

While Therminol heat transfer fluids are compatible with aluminum, bronze and brass alloys, etc., the use of these metals should be kept to a minimum because of their loss of mechanical strength at higher temperatures.

Due to their temperature limitations, nonmetallics (plastics and elastomers) are not recommended for materials of construction in heat transfer systems.

## Expansion tank and venting arrangements

Usually, the expansion tank is installed at the highest point in the system and is connected to the suction side of the pumps. It should serve as the main venting point of the system, as well as provide for system fluid expansion, which can be 25% or more depending on fluid choice and on the operating temperature range. All vent lines should be routed to a safe location.

The double-drop leg expansion tank (see Figures A and B on page 9) provides greater flexibility of operation than a single-leg tank. From a single-leg expansion tank, venting of noncondensables (e.g., water) is often difficult in heating systems as is purging of air/water on start-up. A double-leg expansion tank provides uninterrupted flow on start-up and significantly improves the venting capability of the system.

Experience indicates that systems with expansion tanks open to the atmosphere have fluid-contamination problems related to oxidation and excessive moisture. Therefore, open expansion tanks should not be employed in systems using Therminol heat transfer fluids.

An effective way to minimize fluid oxidation is to blanket the system with an inert gas (e.g., nitrogen) as shown in Figure A. When using a nitrogen blanket, moisture should be driven off from the fluid before the gas pressure is set. If this is not practical, air contact can be minimized by a cold seal trap arrangement as shown in Figure B. Low boilers and moisture can collect in the cold seal trap, so the fluid in the trap should be discarded periodically.

The expansion tank should be sized so that it is one-fourth full when the system is at ambient temperature and three-fourths full when the system is at operating temperature.

It should be fitted with a high-pressure sight glass at the full range and with a minimum-level switch to shut off the heater and the pump in the event of accidental fluid loss.

As is good design practice with all large components in a heat transfer system, the expansion tank should be fitted with a pressure relief device, such as a relief valve, rupture disk or vent traps. These can relieve excessive pressures to prevent damage or rupture of the expansion tank. These devices should be sized to vent the expansion tank vapor space in anticipation of the most severe venting condition. Industrial standards for relief devices and sizing are covered in API Standards 520–527.

## Pipework

The piping layout for systems using Therminol heat transfer fluids should be sized to provide the normal required flow rate at an economical pressure drop. Because the system will undergo temperature changes, adequate flexibility to relieve thermal expansion and contraction stresses is essential. Schedule 40 carbon steel pipe (ASTM A53 for welded and seamless or ASTM A106 for seamless) should be used throughout the system. The tendency to leak through joints and fittings is characteristic of most organic heat transfer fluids (including Therminol fluids) unless these fittings are very tight. Control of piping leaks is especially important since fluid-soaked insulation poses a more serious hazard than the leaking fluid itself (see insulation section on page 9). The best way to prevent piping leakage is to weld all connections. Use of threaded fittings is strongly discouraged due to their tendency to leak. Where access is necessary, raised-face flanges with weld neck joints (ANSI B16.5 Class 300) or equivalent raised-face flanges are recommended.

Recommended flange gasketing for high-temperature heat transfer fluid systems is the spiral-wound type conforming to ANSI B16.20. Standard materials for spiral-wound flange gaskets are Type 304 stainless steel and flexible graphite filler. For leak-free performance of spiral-wound gaskets, the following points are important: use of raised-face flanges (125 RMS finish) and alloy steel bolting with copper- or nickel-based thread lubricants, uniform compression of the gasket during bolt pull-up, and flange faces clear of imperfections and parallel.

Other requirements for safe design of piping are found in the Chemical Plant and Petroleum Refining Piping Code, ANSI B31.3.

# Expansion tank and cold seal trap

For start-up or venting operations, valves B, C, D and F are opened. Valve A can be throttled to ensure fluid flow through the expansion tank. Valve E should be throttled to limit the inert gas flow through the expansion tank.

For normal operation, valves B, C and F are closed, and valves A, D and E are open. This arrangement provides normal return flow to pump suction with an open static head line from tank to pump. Bypass line through valve D minimizes thermal siphon to expansion tank.

Figure A. Suggested inert gas arrangement for expansion tank

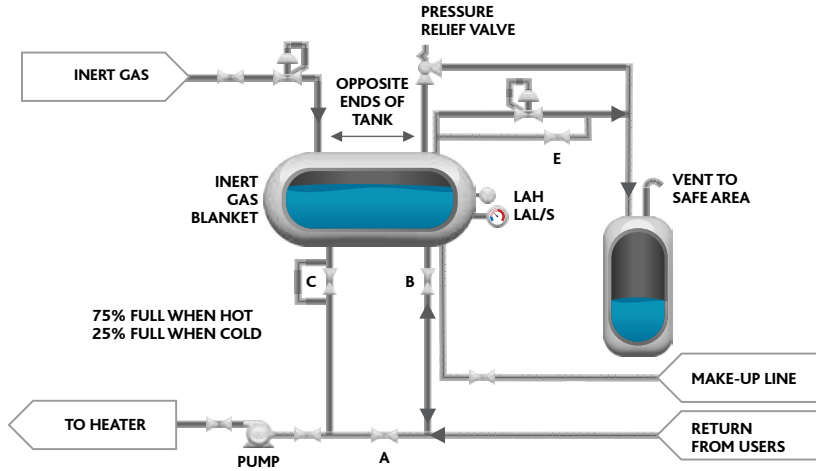
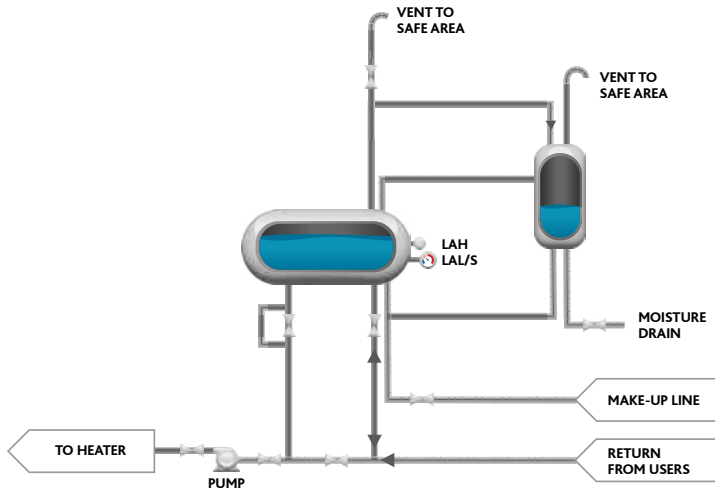

Figure B. Suggested cold seal trap arrangement for expansion tank



## Insulation

Normal high-temperature insulation, such as calcium silicate, mineral wool and cellular glass, can be used in Therminol fluid service. **However, fluid-saturated insulation is a potential fire hazard at the temperatures often encountered while operating a heat transfer fluid system.**

Heat transfer fluids can exhibit a slow oxidation reaction with air in the presence of porous insulating materials.

This phenomenon can be minimized through the use of cellular glass insulation, which resists saturation by the heat transfer fluid due to its closed cell nature.

The following additional suggestions may help minimize the fire hazard potential in insulation systems:

- Install and maintain a leak-free piping system.
- Reduce the number of flanges and other mechanical joints in initial system design.
- Use suggested piping specifications.
- If a leak develops, remove the insulation and contain and control the fluid until the leak can be repaired.
- On vertical runs of pipe where occasional leaks can develop at flanges, install protective tight-fitting caps to divert any fluid leakage outside the insulation.
- Install valve stems horizontally or in a downward position so that any stem leakage does not enter the insulation.
- **Always consult your insulation supplier and insurance company for additional suggestions on reducing fire hazards in insulation.**

## Valves

Cast or forged steel valves with 13-chrome trim are satisfactory for systems using Therminol fluids. Globe valves with an outside screw (as a protection against high temperatures) should be used throughout the system when tight sealing of Therminol fluids is desired. Gate valves are acceptable for Therminol fluid service; however, they should not be relied on to provide reliable positive shutoff.

The use of metal-bellows valve stem seals is increasing and should minimize leakage.

## Packing

Various types of high-temperature packing have been used to seal valve stems and pump shafts in high-temperature Therminol fluid service.

Excellent service life has been achieved through the use of graphite-based packing (as long as said packing contains no soluble organic binders). Generally, a minimum of five rings of packing is specified on valve stems to ensure a reasonable seal. Mechanical seals or ring-shaped flexible graphite packing gives the best service for pumps.

## Controls

Controls for heating systems using Therminol heat transfer fluids should be installed both on the heater itself and on the energy-using units.

Install heater controls to regulate the firing mechanism in direct proportion to the required output. These controls should increase or decrease the heat input to maintain Therminol fluid at the operating temperature required by the energy demand. Small units may be operated satisfactorily by relatively simple "on-off" or "high-low" controllers. However, units of all sizes will operate more uniformly if equipped with modulating temperature controls.

Install user controls to regulate the flow of the heat transfer fluid in proportion to the energy consumption of the equipment. In a multiple-user system, separate controls should be installed on each consuming unit to ensure the proper energy delivery.

## Fire protection

**Where fire protection is concerned, it is best to consult your insurance company for guidance and counsel. Likewise, you will want to discuss your fire safety requirements with qualified suppliers of fire protection equipment, as selection and sizing of this equipment is important to safeguard the installation.**

Guidelines that may be followed to improve the overall safety of the installation include the following:

1. The fired heater and other equipment should adhere to the spacing guidelines noted in the NFPA 30. This document gives guidelines for spacing from property lines and important buildings.
2. Where possible, heat transfer systems should be installed in open structures. Closed structures should have explosion-relief construction and adequate ventilation to prevent vapor concentration.

3. The design should consider the benefits of a primary and secondary heating loop to isolate the heat transfer fluid.
4. Automatic, remotely operated (fail safe) valves and automatic pump shutdown should be incorporated to prevent the possibility of the system feeding the fire in the event of a tube rupture. This shutdown could be triggered by a low-flow interlock, a low-expansion tank level interlock, a high stack temperature interlock, or other acceptable means. Provisions should be provided for pressure relief as required.
5. Automatic sprinklering is recommended. Considerations should include the burner front, relief device discharges, control rooms, furnace openings, heat transfer fluid piping systems and vessels, pump locations, escape routes, and operating areas.

Suggested guidelines for fire protection of new fired heater installations are as follows:

- (a) Automatic deluge protection on an area basis (0.3 gpm/ft<sup>2</sup>)
  - (b) Areas requiring the automatic deluge protection to include grade level, burner firing level, the three external vaporizer walls (where vaporizers are closely spaced), and subsequent levels above the burner level
  - (c) Manual fire extinguishers available — Class B
  - (d) Slope grade so runoff is routed away from equipment
  - (e) Supplement automatic systems with 500 gpm (single-fired unit) — 1,000 gpm (multiple furnace) available capacity for hoses
6. Snuffing steam (or other acceptable media) should be provided on the fire box side of any fired heater.  
A commonly used method of preventing fire in the event of tube rupture in fired heaters is to supply steam or CO<sub>2</sub> as a snuffer into the combustion chamber of the heater. Steam snuffer systems should employ a trap to avoid slugging the combustion chamber with water when the system activates or is activated manually. This snuffer system can be automated by the use of an exhaust stack temperature switch, which would energize a solenoid valve and an alarm on excessive temperature rise, thus automatically flooding the chamber with a fire-extinguishing agent.
  7. Consider remote operation of key equipment/valving with manual backup of automated controls.
  8. Electrical equipment should be designed to prevent ingress of heat transfer mists.

9. Insulation (in areas prone to leakage) should be of a type that cannot become saturated with heat transfer fluid. One example would be cellular glass. Care must be taken to verify the insulation material is rated for the system temperature. The piping system should be designed for combustible fluid service at the rated temperature.
10. Discharge lines on all heat transfer fluid relief devices should be:
  - (a) Routed to a safe discharge to atmosphere (not inside a heater room) or routed to an adequate collection system
  - (b) If necessary, protected with additional fire protection so that the fire hazard is minimized at the discharge point

## Safety controls

In addition to activating controls, the system also must be fitted with the proper safety devices to meet local code requirements. Knowledgeable equipment manufacturers should be able to provide guidance on proper safety controls. Safety controls should include, but not be limited to:

- **High-temperature cutoff at the heater outlet** — to shut off the burner in the event of an excessive temperature rise
- **Heater low-flow cutoff** — to shut down the burner should flow rate drop below design rates or should a loss of flow occur due to pump malfunction or failure. Regular automatic ignition controls and flame-failure controls should be included on all burners. In wide-ranging firing, an overfire draft control will save heat losses.
- **Expansion tank low-level shutdown** — to shut off the heater and the pump(s) in the event of accidental fluid loss
- **Expansion tank high-level alarm** — to alert plant operations of system leakage into the fluid
- **Safety relief valves** — All safety relief devices in thermal liquid heat transfer systems should discharge at a point remote from possible ignition sources and away from areas where danger to personnel exists. Pressure relief devices should be placed on the heater outlet, on the expansion tank, and (where appropriate) on system users.
- **Other safety controls** — Electric power failure and instrument air failure safety controls also are desirable. In general, a policy of fail-safe instrumentation and control in the design is essential, using quality indicating and recording gauges with accurate-reading scales calibrated for the specific limits of operation.

# Typical liquid-phase heat systems

## System 1 – The basic system

The transfer of process heat as a liquid offers these benefits to the installation:

- Precise heating levels
- Closer temperature control at each user station
- Minimum cost installations
- Greater operating safety
- Low maintenance costs

Systems using Therminol heat transfer fluids are characterized by their extreme flexibility. A single heater can serve multiple "users" operating at the same or different temperature levels. The systems can be designed to deliver and to remove heat.

With thermal liquid heat transfer systems, there are few problems of condensation, pressure drop and large heat surges associated with vapor systems. The four system diagrams on pages 12–15 illustrate a few of the many arrangements of heat users that can be operated with Therminol fluids.

System 1 is the basic system configuration with a single user operating at heater outlet temperature. The temperature control valve regulates flow of the hot Therminol fluid to meet the user's temperature requirements. The pressure control valve ensures that a minimum flow will be maintained through the heater at all times. This system has maximum temperature flexibility. Note also the heater and the pump safety controls and their connection to the heater flow, the heater outlet temperature and the expansion tank low-liquid level sensors.

User temperature also may be controlled by regulating the fuel supply to the heater. This method sometimes has a very limited turndown and should be used only with a continuous process with small load changes. An adequate flow of Therminol fluid must be maintained in the heater at all times to satisfy the energy balance and to prevent exceeding the maximum bulk and maximum film temperatures of the Therminol heat transfer fluid.

System 1

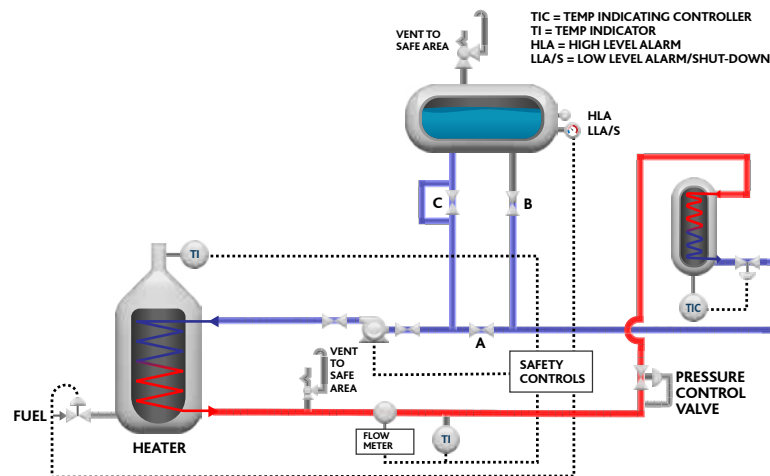

## System 2 – Heating multiple users

This is the same system as System 1, except several heat users are connected to the heater and all operating at the same temperature. To control temperature, each user has a modulating control valve. A single minimum flow bypass valve is used at the end of the piping loop.

**Note:** Refer to System 1 diagram (page 11) for placement of safety controls and fluid relief devices.

### System 2

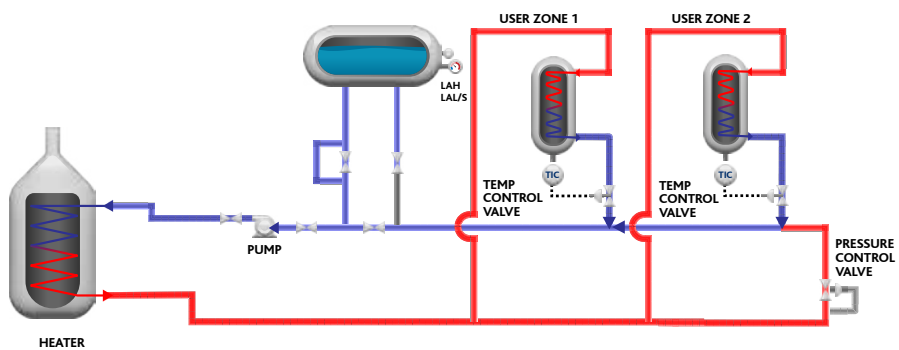

## System 3 – Heating several users at different temperatures

With this arrangement, several heat users at different temperatures may be operated at one time. Each temperature zone has its own recirculating pump located at the user inlet, with the temperature control valve located downstream of the user. A bypass from the zone pump inlet is connected to the user outlet. When the temperature control valve is opened, fresh high-temperature Therminol heat transfer fluid is admitted to the zone where it is mixed and recirculated.

This blending of hot and cold Therminol fluids gives precise temperature control at some temperature below heater outlet temperature.

### System 3

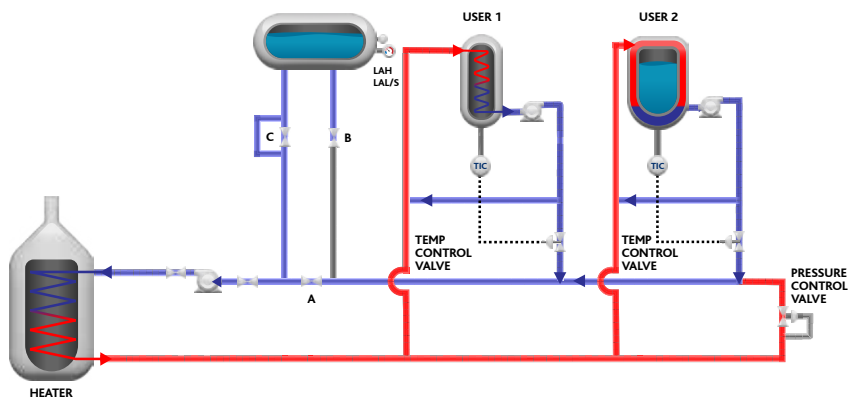

This same principle can be used with System 1 when the user has a very large fluid volume and a small heat load. The main recirculating pump is sized for the heat load through the heaters, while the zone pump is sized to recirculate a larger volume of blended Therminol fluid through the user.

Both of these arrangements will give excellent temperature control, as well as a fast response to system change.

**Note:** Refer to System 1 diagram (page 11) for placement of safety controls and fluid relief devices.

## System 4 – Heating and cooling of a single user

This is a dual system for heating and cooling, using two separate circulating systems for a common user. The temperature controller output is connected in a split-range manner to the cold and hot Therminol fluid control valves. As the output increases from 0% to 55%, the cold valve closes (with a minimum stop to prevent deadheading the cooling zone pump). As the output increases from 45% to 100%, the hot valve opens. The pressure control valve maintains a minimum flow through the heater under all conditions. Even with the slight overlap in the cold and hot valve ranges, this design operates with a minimum of interchange between the two circulating systems.

**Note:** Refer to System 1 diagram (page 12) for placement of safety controls and fluid relief devices.

System 4

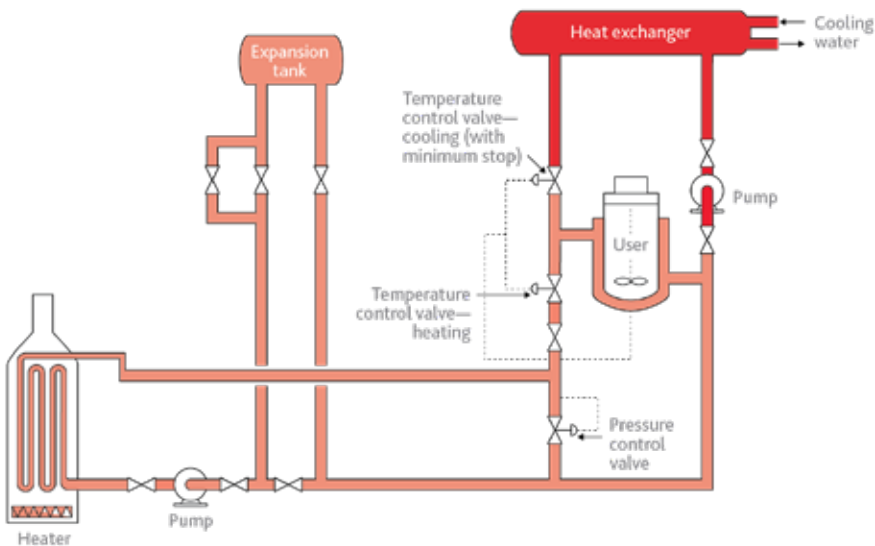

# Start-up

## Suggested start-up procedure for new systems

For a new system or one that returns to service after draining, the following checkpoints are recommended as guides. They are supplemental to those of the heater manufacturers and the recommendations of heat transfer equipment makers and are not intended to supersede or preclude those recommendations. Generally, they apply to the care of the fluid in all sizes and types of systems.

### 1. Check safety and control devices.

For proper installation and functioning, be certain that the range settings are proper for the operation. Manually activate the instruments and apply all tests necessary to ensure proper functioning. For protection of the system and for the expected long service life of the fluid, it is vitally important that all instruments and controls function properly.

### 2. Check for leakage.

3. Remove moisture from the system, using dry compressed air or other suitable means.

### 4. Fill the system with Therminol heat transfer fluid.

(a) Fill the system with Therminol fluid, with all vents to the expansion tank or atmosphere open for air removal. Fill the expansion tank to the desired low level. Where needed, have the steam tracing system operable.

(b) Open all valves, then start the main circulating pump in accordance with the manufacturer's recommendations. Observe the liquid level in the expansion tank, refilling as necessary until the system has been filled. **Allow for thermal expansion of Therminol fluid in determining the cold charge level.** The expansion tank should be adjusted to 70%–75% full when the hot operating temperature is reached.

(c) Circulate the Therminol heat transfer fluid through the system for about 3 to 4 hours to eliminate air pockets and to ensure complete system fill. **Before firing the heater, be sure that the Therminol fluid is circulating freely through the entire system.**

### 5. Start the heater.

(a) Bring the system up to temperature slowly — about 35°C (63°F) per hour. This should prevent thermal shock to heater tubes, tube/heater joints, refractory materials, etc., and will allow operators to check the functioning of instruments and controls. The slow heat-up also will allow moisture trapped in all sections of the system to escape as a vapor. Inert gas should sweep the expansion tank to remove noncondensables and residual moisture. **Hold the temperature above 100°C (212°F) until no signs of moisture remain (e.g., knocking or rattling of pipes, moisture from vents, etc.).**

(b) Bring the system to operating temperature, put the "users" on the line, and place the expansion tank inerting system into operation.

(c) The fluid should generally be analyzed with 24 hours of plant start-up and annually thereafter. Consult your Therminol fluid specialist for specific recommendations for your system.

(d) Check the start-up strainers. If foreign material collects, the strainer should be periodically removed and cleaned. After several days of operation with no foreign material on the strainer, it may be permanently removed. If the start-up strainer is to remain permanently installed, it should be tagged for easy identification.

**Note:** *The system should be heated and cooled for at least two cycles with the screen in place since the resulting expansion and contraction will loosen mill scale.*

# Operating instructions

## Suggested operating instructions for liquid-phase heating systems using Therminol fluids

The following operating suggestions are not intended to supersede or preclude those operating instructions provided by a heater or a system supplier.

### 1. Check safety controls.

In addition to activating controls, the heater also should be fitted with the proper safety controls to meet local code requirements.

### 2. Start-up temperature precautions

- (a) Temperature of fluid at start-up is important; consult your heater and pump supplier for the maximum recommended start-up viscosity. This should correspond with the minimum permitted fluid temperature. Failure to comply with supplier recommendations may lead to equipment damage.
- (b) If start-up must be made at temperatures below the fluid pumpability limit, the fluid should be heated in a safe way (i.e., with steam or electrical tracing).
- (c) One way of avoiding start-up temperature problems in cold weather is to keep the system idling at 105°C (221°F) — especially for those fluids that can solidify or become too thick to pump.

### 3. Procedure for start-up (cold fluid)

- (a) When the start-up temperature is correct, start the circulating pump and check the expansion tank level to see that the Therminol heat transfer fluid is at the proper cold-start level (usually 25% full). Activate the inert gas sweeping system at the expansion tank.
- (b) Start burner at the "low" flame setting and continue full circulation until the bulk temperature of Therminol fluid reaches 105°C (221°F).
- (c) Turn heater to full or proceed with the heater manufacturer's heat-up schedule.

### 4. Procedure for start-up (hot fluid)

After an automatic shutdown by the safety controls, fluid should still be above 105°C (221°F).

- (a) Determine the cause of the shutdown and rectify the conditions that caused the shutdown.
- (b) Run the circulating pump to turn the system volume over a number of times to eliminate any vapor pockets formed while the fluid has remained static in the heater.
- (c) Start the burner at the low flame setting. When the flame is stabilized, the heater can be turned to full fire.

### 5. Procedure for shutdown

- (a) Shut off burner completely with the circulating pump still operating. Continue to run the pump at full capacity to dissipate residual heat in the heater.
- (b) When the heater has cooled to the manufacturer's recommended low temperature, shut off the circulating pump and switch off all heater electrical controls.
- (c) Caution must be exercised during shutdown to ensure that no area in the system is totally and completely isolated. This will prevent a vacuum from forming, which could damage (implode) equipment.

## 6. Planned maintenance

Regular maintenance inspection schedules should include the manufacturer's recommendations for the heater and the components, as well as inspection of the Therminol heat transfer fluid. The following maintenance suggestions are not meant to supersede or preclude those maintenance instructions provided by the system designers or equipment manufacturers:

- (a) Lubricate moving parts.
- (b) Check operating fidelity and the accuracy of the readings of safety controls and temperature limit controls.
- (c) Inspect heater tubes, burner and refractory linings.
- (d) Periodically service the heater.
- (e) Inspect the fluid cooling at the circulating pump.
- (f) Repack stuffing boxes according to the manufacturer's specification.
- (g) Inspect all sealed surfaces, i.e., flanges, valve packings, etc., for evidence of leakage. Repair leaking areas to prevent more serious fluid loss and to reduce safety hazards.
- (h) Fluid samples for analysis should be taken within 24 hours of plant start-up and annually thereafter. Consult your Therminol fluid specialist for specific recommendations for your system. Eastman will provide free sample analysis and will then indicate the necessary corrective action required should results be outside the acceptable values for used fluid. Special heat transfer fluid sampling kits can be requested through your Therminol fluid specialist by calling Eastman technical service at 800-433-6997 or by visiting [therminol.com](http://therminol.com) or [fluidgenius.net](http://fluidgenius.net).

## Safe handling and disposal

Animal toxicity studies and manufacturing experience indicate that no special precautions are required in the handling of these products at ambient temperatures. Acute toxicity studies indicate that most of the Therminol heat transfer fluids are practically nontoxic by ingestion of single doses. Although tests suggest that these materials are probably not irritating to skin, it is good practice to avoid repeated and prolonged skin contact with any industrial chemical, heat transfer fluid or petroleum product. Vapors or spray mists of the material, on the other hand, while not dangerously toxic, can give rise to discomfort, and thermal decomposition caused by excessive heating may generate more irritating fumes. Systems should be made as leak tight as possible and any spillage absorbed and/or removed. Repairs to leaks of hot fluid should be carried out under well-ventilated conditions. Extra care is necessary when the system is at high temperature. Most repairs and maintenance activities should be performed at low temperatures.

More data are available for each product in the Safety Data Sheets, which are available on request or directly from the Therminol website. While it is believed that Therminol heat transfer fluids pose no serious problems with respect to the environment, as a concerned supplier to the industry, Eastman urges the user to maintain a tight system, to correct leakage promptly, and to exercise care in the handling and disposal of this and all other such products. A consistent maintenance program not only protects the environment but also keeps employees comfortable, the working area clean and the system running smoothly.

### Important warning

Heat transfer fluids are intended only for indirect heating purposes. Under no circumstances should Therminol heat transfer fluids contact or, in any way, contaminate food, animal feed, food products, food packaging materials, pharmaceuticals, or any items that may directly or indirectly be ultimately ingested by humans. Any fluid contact may contaminate these items or products to the extent that their destruction may be required. Precautions against ignitions and fires also should be taken with these fluids.

# Resistance of valves and fittings

A simple way to account for the resistance offered to flow by valves and fittings is to add to the length of pipe in the line a length that will give a pressure drop equal to that which occurs in the valves and fittings in the line.

**Example:** The dotted line shows that the resistance of a 6-inch standard elbow is equivalent to approximately 16 feet of 6-inch standard steel pipe.

## Resistance of valves and fittings

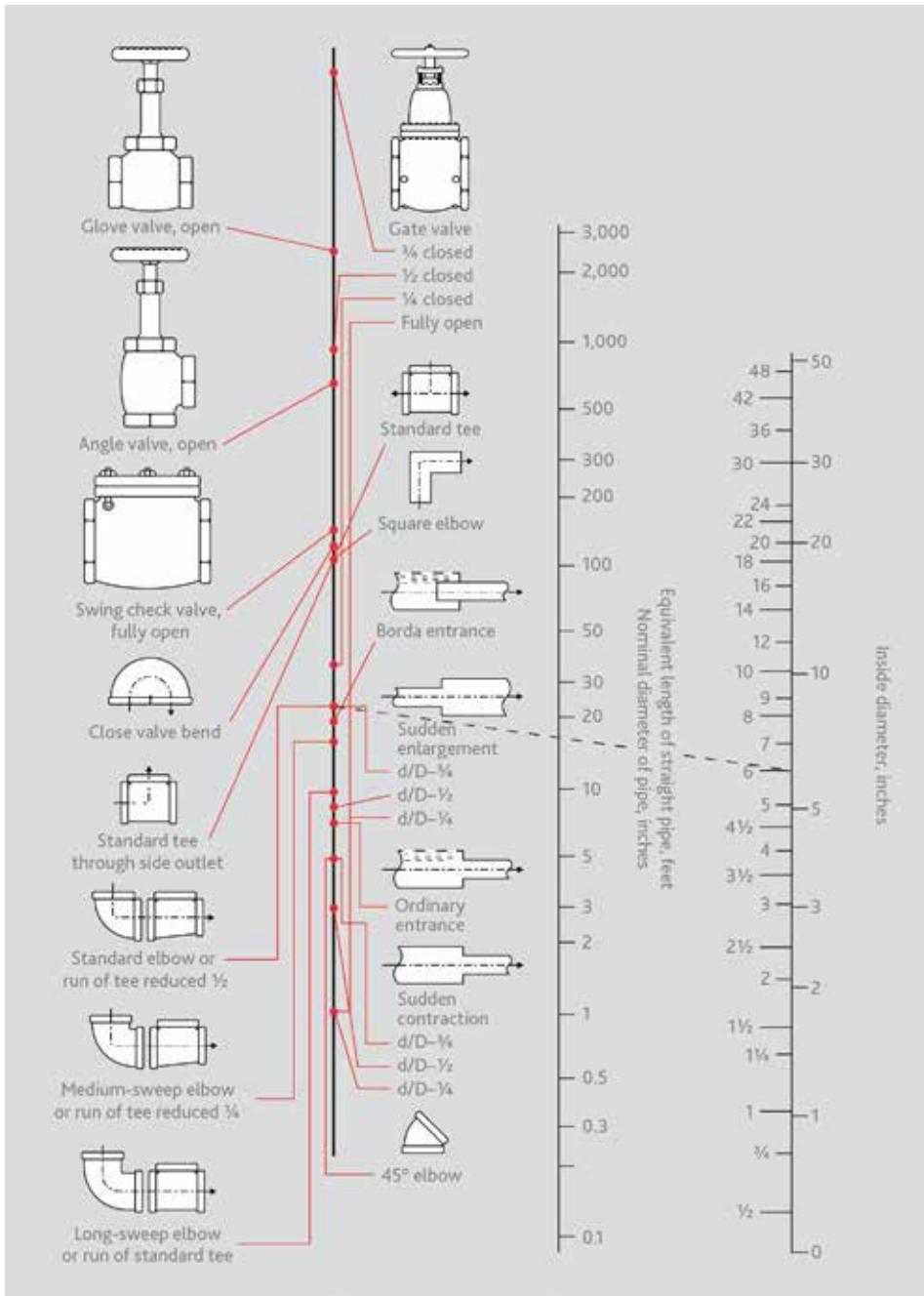

# Steel pipe dimensions

## Capacities and weights\*

| Nominal pipe size, in. | Outside diam., in. | Schedule no. | Wall thickness, in. | Inside diam., in. | Cross-sectional area metal, sq ft | Inside sectional area, sq ft | Circumference, ft, or surface sq ft per ft of length |          | Capacity at 1 ft per sec velocity |                 | Weight of pipe per ft, lb |
|------------------------|--------------------|--------------|---------------------|-------------------|-----------------------------------|------------------------------|--|----------|-----------------------------------|-----------------|---------------------------|
|                        |                    |              |                     |                   |                                   |                              | Outside  | Inside   | U.S. gal per min                  | Lb per hr water |                           |
| 1/8                    | 0.405              | 40           | 0.068               | 0.269             | 0.072                             | 0.00040                      | 0.106  | 0.075    | 0.179                             | 89.5            | 0.25                      |
|                        |                    | 80           | 0.095               | 0.215             | 0.093                             | 0.00025                      | 0.106  | 0.0563   | 0.112                             | 56.0            | 0.32                      |
| 1/4                    | 0.540              | 40           | 0.088               | 0.364             | 0.125                             | 0.00072                      | 0.141  | 0.0954   | 0.323                             | 161.5           | 0.43                      |
|                        |                    | 80           | 0.119               | 0.302             | 0.157                             | 0.00050                      | 0.141  | 0.0792   | 0.224                             | 112.0           | 0.54                      |
| 3/8                    | 0.675              | 40           | 0.091               | 0.493             | 0.167                             | 0.00133                      | 0.177  | 0.1293   | 0.596                             | 298.0           | 0.57                      |
|                        |                    | 80           | 0.126               | 0.423             | 0.217                             | 0.00098                      | 0.177  | 0.1110   | 0.440                             | 220.0           | 0.74                      |
| 1/2                    | 0.840              | 40           | 0.109               | 0.622             | 0.250                             | 0.00211                      | 0.220  | 0.1630   | 0.945                             | 472.5           | 0.85                      |
|                        |                    | 80           | 0.147               | 0.546             | 0.320                             | 0.00163                      | 0.220  | 0.1430   | 0.730                             | 365.0           | 1.09                      |
|                        |                    | 160          | 0.187               | 0.466             | 0.384                             | 0.00118                      | 0.220  | 0.1220   | 0.529                             | 264.5           | 1.31                      |
| 3/4                    | 1.050              | 40           | 0.113               | 0.824             | 0.333                             | 0.00371                      | 0.275  | 0.2158   | 1.665                             | 832.5           | 1.13                      |
|                        |                    | 80           | 0.154               | 0.742             | 0.433                             | 0.00300                      | 0.275  | 0.1942   | 1.345                             | 672.5           | 1.48                      |
|                        |                    | 160          | 0.218               | 0.614             | 0.570                             | 0.00206                      | 0.275  | 0.1610   | 0.924                             | 462.0           | 1.94                      |
| 1                      | 1.315              | 40           | 0.133               | 1.049             | 0.494                             | 0.00600                      | 0.344  | 0.2745   | 2.690                             | 1,345.0         | 1.68                      |
|                        |                    | 80           | 0.179               | 0.957             | 0.639                             | 0.00499                      | 0.344  | 0.2505   | 2.240                             | 1,120.0         | 2.17                      |
|                        |                    | 160          | 0.250               | 0.815             | 0.837                             | 0.00362                      | 0.344  | 0.2135   | 1.625                             | 812.5           | 2.85                      |
| 1 1/4                  | 1.660              | 40           | 0.140               | 1.380             | 0.669                             | 0.01040                      | 0.435  | 0.362    | 4.57                              | 2,285.0         | 2.28                      |
|                        |                    | 80           | 0.191               | 1.278             | 0.881                             | 0.00891                      | 0.435  | 0.335    | 3.99                              | 1,995.0         | 3.00                      |
|                        |                    | 160          | 0.250               | 1.160             | 1.107                             | 0.00734                      | 0.435  | 0.304    | 3.29                              | 1,645.0         | 3.77                      |
| 1 1/2                  | 1.900              | 40           | 0.145               | 1.610             | 0.799                             | 0.01414                      | 0.498  | 0.422    | 6.34                              | 3,170.0         | 2.72                      |
|                        |                    | 80           | 0.200               | 1.500             | 1.068                             | 0.01225                      | 0.498  | 0.393    | 5.49                              | 2,745.0         | 3.64                      |
|                        |                    | 160          | 0.281               | 1.338             | 1.429                             | 0.00976                      | 0.498  | 0.350    | 4.38                              | 2,190.0         | 4.86                      |
| 2                      | 2.375              | 40           | 0.154               | 2.067             | 1.075                             | 0.02330                      | 0.622  | 0.542    | 10.45                             | 5,225.0         | 3.66                      |
|                        |                    | 80           | 0.218               | 1.939             | 1.477                             | 0.02050                      | 0.622  | 0.508    | 9.20                              | 4,600.0         | 5.03                      |
|                        |                    | 160          | 0.343               | 1.689             | 2.190                             | 0.01556                      | 0.622  | 0.442    | 6.97                              | 3,485.0         | 7.45                      |
| 2 1/2                  | 2.875              | 40           | 0.203               | 2.469             | 1.704                             | 0.03322                      | 0.753  | 0.647    | 14.92                             | 7,460.0         | 5.80                      |
|                        |                    | 80           | 0.276               | 2.323             | 2.254                             | 0.02942                      | 0.753  | 0.609    | 13.20                             | 6,600.0         | 7.67                      |
|                        |                    | 160          | 0.375               | 2.125             | 2.945                             | 0.02463                      | 0.753  | 0.557    | 11.07                             | 5,535.0         | 10.0                      |
| 3                      | 3.500              | 40           | 0.216               | 3.068             | 2.228                             | 0.05130                      | 0.917  | 0.804    | 23.00                             | 11,500.0        | 7.58                      |
|                        |                    | 80           | 0.300               | 2.900             | 3.016                             | 0.04587                      | 0.917  | 0.760    | 20.55                             | 10,275.0        | 10.3                      |
|                        |                    | 160          | 0.437               | 2.626             | 4.205                             | 0.03761                      | 0.917  | 0.688    | 16.90                             | 8,450.0         | 14.3                      |
| 3 1/2                  | 4.000              | 40           | 0.226               | 3.548             | 2.680                             | 0.06870                      | 1.047  | 0.930    | 30.80                             | 15,400.0        | 9.11                      |
|                        |                    | 80           | 0.318               | 3.364             | 3.678                             | 0.06170                      | 1.047  | 0.882    | 27.70                             | 13,850.0        | 12.5                      |
| 4                      | 4.500              | 40           | 0.237               | 4.026             | 3.173                             | 0.08840                      | 1.178  | 1.055    | 39.6                              | 19,800.0        | 10.8                      |
|                        |                    | 80           | 0.337               | 3.826             | 4.407                             | 0.07986                      | 1.178  | 1.002    | 35.8                              | 17,900.0        | 15.0                      |
|                        |                    | 120          | 0.437               | 3.626             | 5.578                             | 0.07170                      | 1.178  | 0.950    | 32.2                              | 16,100.0        | 19.0                      |
|                        |                    | 160          | 0.531               | 3.438             | 6.621                             | 0.06447                      | 1.178  | 0.901    | 28.9                              | 14,450.0        | 22.6                      |
| 5                      | 5.563              | 40           | 0.258               | 5.047             | 4.304                             | 0.1390                       | 1.456  | 1.322    | 62.3                              | 31,150.0        | 14.7                      |
|                        |                    | 80           | 0.375               | 4.813             | 6.112                             | 0.1263                       | 1.456  | 1.263    | 57.7                              | 28,850.0        | 20.8                      |
|                        |                    | 120          | 0.500               | 4.563             | 7.953                             | 0.1136                       | 1.456  | 1.197    | 51.0                              | 25,500.0        | 27.1                      |
|                        |                    | 160          | 0.625               | 4.313             | 9.696                             | 0.1015                       | 1.456  | 1.132    | 45.5                              | 22,750.0        | 33.0                      |
| 6                      | 6.625              | 40           | 0.280               | 6.065             | 5.584                             | 0.2006                       | 1.734  | 1.590    | 90.0                              | 45,000.0        | 19.0                      |
|                        |                    | 80           | 0.432               | 5.761             | 8.405                             | 0.1810                       | 1.734  | 1.510    | 81.1                              | 40,500.0        | 28.6                      |
|                        |                    | 120          | 0.562               | 5.501             | 10.71                             | 0.1650                       | 1.734  | 1.445    | 73.9                              | 36,950.0        | 36.4                      |
|                        |                    | 160          | 0.718               | 5.189             | 13.32                             | 0.1469                       | 1.734  | 1.360    | 65.8                              | 32,900.0        | 45.3                      |
| 8                      | 8.625              | 20           | 0.250               | 8.125             | 6.570                             | 0.3601                       | 2.258  | 2.130    | 161.5                             | 80,750.0        | 22.4                      |
|                        |                    | 30           | 0.277               | 8.071             | 7.260                             | 0.3553                       | 2.258  | 2.115    | 159.4                             | 79,700.0        | 24.7                      |
|                        |                    | 40           | 0.322               | 7.981             | 8.396                             | 0.3474                       | 2.258  | 2.090    | 155.7                             | 77,850.0        | 28.6                      |
|                        |                    | 60           | 0.406               | 7.813             | 10.48                             | 0.3329                       | 2.258  | 2.050    | 149.4                             | 74,700.0        | 35.7                      |
|                        |                    | 80           | 0.500               | 7.625             | 12.76                             | 0.3171                       | 2.258  | 2.000    | 142.3                             | 71,150.0        | 43.4                      |
|                        |                    | 100          | 0.593               | 7.439             | 14.96                             | 0.3018                       | 2.258  | 1.947    | 135.3                             | 67,650.0        | 50.9                      |
|                        |                    | 120          | 0.718               | 7.189             | 17.84                             | 0.2819                       | 2.258  | 1.883    | 126.5                             | 63,250.0        | 60.7                      |
|                        |                    | 160          | 0.812               | 7.001             | 19.93                             | 0.2673                       | 2.258  | 1.835    | 120.0                             | 60,000.0        | 67.8                      |
| 160                    | 0.906              | 6.813        | 21.97               | 0.2532            | 2.258                             | 1.787                        | 113.5  | 56,750.0 | 74.7                              |                 |                           |

\*Pipe dimensions are taken from ANSI B36.10.

# Engineering conversion factors

| Multiply                                | By                     | To obtain                               |
|---|------------------------|---|
| atmospheres                             | 14.70                  | lb/sq in.                               |
| atmospheres                             | 760                    | mm Hg                                   |
| atmospheres                             | 29.92                  | in. Hg                                  |
| atmospheres                             | 33.90                  | ft of water                             |
| British thermal units                   | $3.93 \times 10^{-4}$  | hp hr                                   |
| British thermal units                   | $2.930 \times 10^{-4}$ | kw hr                                   |
| Btu/hr                                  | $3.927 \times 10^{-4}$ | hp                                      |
| Btu/(hr sq ft °F)                       | $1.356 \times 10^{-4}$ | gram-cal/sec cm <sup>2</sup> °C         |
| Btu/(hr sq ft °F)                       | $2.035 \times 10^{-3}$ | watts/sq in. °F                         |
| (Btu/hr sq ft)/(°F/in.)                 | $3.445 \times 10^{-4}$ | (gram-cal/sec cm <sup>2</sup> )/(°C/cm) |
| (Btu/hr sq ft)/(°F/ft)                  | 0.0173                 | (watts/cm <sup>2</sup> )/(°C/cm)        |
| (Btu/hr sq ft)/(°F/ft)                  | 14.88                  | (gram-cal/hr cm <sup>2</sup> )/(°C/cm)  |
| Btu/lb °F                               | 1.0                    | gram-cal/gram°C                         |
| Btu/sec                                 | 778.2                  | ft lb/sec                               |
| Btu/sec                                 | 1.4147                 | hp                                      |
| Btu/sec                                 | 1.0549                 | kw                                      |
| Btu/sec                                 | 107.6                  | kg-m/sec                                |
| Btu/sq ft                               | 0.2712                 | gram-cal/cm <sup>2</sup>                |
| Btu/sq ft                               | 2.712                  | kg-cal/m <sup>2</sup>                   |
| centimeters                             | 0.3937                 | in.                                     |
| centimeters                             | 0.0328                 | ft                                      |
| cm Hg                                   | 0.01316                | atm                                     |
| cm Hg                                   | 0.1934                 | lb/sq in.                               |
| cm Hg                                   | 27.85                  | lb/sq ft                                |
| cm Hg                                   | 136.0                  | kg/sq m                                 |
| cm Hg                                   | 5.353                  | in. of water                            |
| cm Hg                                   | 0.4461                 | ft of water                             |
| cm/°C                                   | 0.2187                 | in./°F                                  |
| cm/sec                                  | 1.969                  | ft/min                                  |
| cm/sec                                  | 0.03281                | ft/sec                                  |
| cm/sec                                  | 0.036                  | km/hr                                   |
| cm/sec                                  | 0.60                   | m/min                                   |
| cm/sec                                  | 0.02237                | mph                                     |
| centipoises                             | 2.42                   | lb/ft hr                                |
| cm <sup>3</sup>                         | 0.06102                | cu in.                                  |
| cm <sup>3</sup>                         | $3.531 \times 10^{-5}$ | cu ft                                   |
| cm <sup>3</sup>                         | $2.642 \times 10^{-4}$ | gal                                     |
| cm <sup>3</sup> /sec                    | $2.119 \times 10^{-3}$ | cu ft/min                               |
| cm <sup>3</sup> /sec                    | 0.0864                 | m <sup>3</sup> /day                     |
| cm <sup>3</sup> /sec                    | 0.01585                | gal/min                                 |
| cm <sup>3</sup> /sec                    | 3.6                    | L/hr                                    |
| cm <sup>3</sup> /gram                   | 0.01602                | cu ft/lb                                |
| cm <sup>3</sup> /gram mol               | 0.01602                | cu ft/lb mol                            |
| cu ft                                   | 7.481                  | gal                                     |
| cu ft                                   | 28.32                  | L                                       |
| cu ft                                   | 62.43                  | lb of water                             |
| ft of water                             | 62.43                  | lb/sq ft                                |
| ft of water                             | 0.4335                 | lb/sq in.                               |
| ft/min                                  | 0.508                  | cm/sec                                  |
| gallons (Imperial)                      | 1.201                  | gal (U.S.)                              |
| gal (U.S.)                              | 231                    | cu in.                                  |
| gal (U.S.)                              | 3785                   | cm <sup>3</sup>                         |
| gal (U.S.)                              | 3.785                  | L                                       |
| gal/hr                                  | $3.71 \times 10^{-5}$  | cu ft/sec                               |
| gal/min                                 | $2.228 \times 10^{-3}$ | cu ft/sec                               |
| gal/min                                 | 0.227                  | m <sup>3</sup> /hr                      |
| gal/min                                 | 0.06309                | L/sec                                   |
| gal/min of water                        | 500.8                  | lb/hr of water                          |
| grams                                   | $2.205 \times 10^{-3}$ | lb                                      |
| gram-cal                                | $3.968 \times 10^{-4}$ | Btu                                     |
| gram-cal/gram                           | 1.8                    | Btu/lb                                  |
| gram-cal/gram mol                       | 1.8                    | Btu/lb mol                              |
| gram-cal/gram°C                         | 1.0                    | Btu/lb°F                                |
| (gram-cal/sec cm <sup>2</sup> )/(°C/cm) | $2.903 \times 10^3$    | (Btu/hr sq ft)/(°F/in.)                 |

| Multiply               | By                     | To obtain             |
|------------------------|------------------------|-----------------------|
| hp (boiler)            | $3.3479 \times 10^4$   | Btu/hr                |
| hp (boiler)            | 9.804                  | kw                    |
| hp hr                  | $2.545 \times 10^3$    | Btu                   |
| hp hr                  | 0.7457                 | kw hr                 |
| inches                 | 2.54                   | cm                    |
| in. Hg                 | 0.03342                | atm                   |
| in. Hg                 | 1.133                  | ft of water           |
| in. Hg                 | 0.4912                 | lb/sq in.             |
| in. of water           | $2.458 \times 10^{-3}$ | atm                   |
| in. of water           | 0.07355                | in. Hg                |
| kg/m <sup>3</sup>      | 0.06243                | lb/cu ft              |
| kilowatts              | 1.341                  | hp                    |
| kw hr                  | $3.413 \times 10^3$    | Btu                   |
| kw hr                  | 1.341                  | hp hr                 |
| L                      | 0.2642                 | gal (U.S.)            |
| L                      | 1.057                  | qt (liq)              |
| L/min                  | 15.851                 | gal/hr                |
| m                      | 3.281                  | ft                    |
| m                      | 39.37                  | in.                   |
| m/sec                  | 196.8                  | ft/min                |
| m/sec                  | 2.237                  | mph                   |
| ounces                 | 28.35                  | grams                 |
| poises                 | 1                      | gram/cm sec           |
| pounds                 | 453.6                  | grams                 |
| lb of water            | 0.01602                | cu ft                 |
| lb of water            | 0.1198                 | gal                   |
| lb/ft hr               | 0.413                  | centipoises           |
| lb/gal                 | 0.1198                 | grams/cm <sup>3</sup> |
| lb/sq ft               | 0.01602                | ft of water           |
| lb/sq ft               | 4.882                  | kg/m <sup>2</sup>     |
| lb/sq in.              | 0.06804                | atm                   |
| lb/sq in.              | 2.307                  | ft of water           |
| lb/sq in.              | 2.036                  | in. Hg                |
| lb/sq in. <sup>5</sup> | 1.7                    | mm Hg                 |
| lb/sq in.              | 703.1                  | kg/sq m               |
| refrigeration—std. ton | 200                    | Btu/min               |
| cm <sup>2</sup>        | $1.076 \times 10^{-3}$ | sq ft                 |
| cm <sup>2</sup>        | 0.1550                 | sq in.                |
| sq ft                  | 929                    | cm <sup>2</sup>       |
| sq ft                  | 144                    | sq in.                |
| sq ft                  | 0.0929                 | sq m                  |
| sq in.                 | 6.452                  | cm <sup>2</sup>       |
| sq in.                 | $6.944 \times 10^{-3}$ | sq ft                 |
| sq in.                 | $6.452 \times 10^{-4}$ | sq m                  |
| sq m                   | 10.76                  | sq ft                 |
| temperature °C + 273   | 1.0                    | abs temp. K           |
| temperature °C + 178   | 1.8                    | temp. °F              |
| temperature °F + 460   | 1.0                    | abs temp. R           |
| temperature °F - 32.0  | .5555                  | temp. °C              |
| tons (long)            | $1.016 \times 10^3$    | kg                    |
| tons (long)            | $2.24 \times 10^3$     | lb                    |
| tons (metric)          | $2.205 \times 10^3$    | lb                    |
| tons (short)           | 907.2                  | kg                    |
| tons (short)           | $2 \times 10^3$        | lb                    |
| watts                  | 0.05692                | Btu/min               |
| watts                  | 44.26                  | ft lb/min             |
| watts                  | $1.341 \times 10^{-3}$ | hp                    |
| watt hr                | 3.413                  | Btu                   |
| week                   | 168                    | hr                    |
| week                   | $1.008 \times 10^4$    | min                   |
| week                   | $6.048 \times 10^5$    | sec                   |
| years (common)         | $8.76 \times 10^3$     | hr                    |

# Average properties of tubes

| Diameter      |               | Thickness |          | External           |                              |  | Internal                |                                  |                             |                    |                                     |
|---------------|---------------|-----------|----------|--------------------|------------------------------|--|-------------------------|----------------------------------|-----------------------------|--------------------|-------------------------------------|
| External, in. | Internal, in. | BWG gauge | NOM wall | Circumference, in. | Surface per lineal ft, sq ft | Lineal ft of tube per sq ft of surface | Transverse area, sq in. | Volume or capacity per lineal ft |                             |                    | Length of tube containing one cu ft |
|               |               |           |          |                    |                              |  |                         | Cubic in.                        | Cubic ft also area in sq ft | United States, gal |                                     |
| 5/8           | 0.527         | 18        | 0.049    | 1.9635             | 0.1636                       | 6.1115                                 | 0.218                   | 2.616                            | 0.0015                      | 0.011              | 661                                 |
|               | 0.495         | 16        | 0.065    |                    |                              |  | 0.193                   | 2.316                            | 0.0013                      | 0.010              | 746                                 |
|               | 0.459         | 14        | 0.083    |                    |                              |  | 0.166                   | 1.992                            | 0.0011                      | 0.009              | 867                                 |
| 3/4           | 0.652         | 18        | 0.049    | 2.3562             | 0.1963                       | 5.0930                                 | 0.334                   | 4.008                            | 0.0023                      | 0.017              | 431                                 |
|               | 0.620         | 16        | 0.065    |                    |                              |  | 0.302                   | 3.624                            | 0.0021                      | 0.016              | 477                                 |
|               | 0.584         | 14        | 0.083    |                    |                              |  | 0.268                   | 3.216                            | 0.0019                      | 0.014              | 537                                 |
|               | 0.560         | 13        | 0.095    |                    |                              |  | 0.246                   | 2.952                            | 0.0017                      | 0.013              | 585                                 |
| 1             | 0.902         | 18        | 0.049    | 3.1416             | 0.2618                       | 3.8197                                 | 0.639                   | 7.668                            | 0.0044                      | 0.033              | 225                                 |
|               | 0.870         | 16        | 0.065    |                    |                              |  | 0.595                   | 7.140                            | 0.0041                      | 0.031              | 242                                 |
|               | 0.834         | 14        | 0.083    |                    |                              |  | 0.546                   | 6.552                            | 0.0038                      | 0.028              | 264                                 |
|               | 0.810         | 13        | 0.095    |                    |                              |  | 0.515                   | 6.180                            | 0.0036                      | 0.027              | 280                                 |
| 1 1/4         | 1.152         | 18        | 0.049    | 3.9270             | 0.3272                       | 3.0558                                 | 1.075                   | 12.90                            | 0.0075                      | 0.056              | 134                                 |
|               | 1.120         | 16        | 0.065    |                    |                              |  | 0.985                   | 11.82                            | 0.0068                      | 0.051              | 146                                 |
|               | 1.084         | 14        | 0.083    |                    |                              |  | 0.923                   | 11.08                            | 0.0064                      | 0.048              | 156                                 |
|               | 1.060         | 13        | 0.095    |                    |                              |  | 0.882                   | 10.58                            | 0.0061                      | 0.046              | 163                                 |
|               | 1.032         | 12        | 0.109    |                    |                              |  | 0.836                   | 10.03                            | 0.0058                      | 0.043              | 172                                 |
| 1 1/2         | 1.402         | 18        | 0.049    | 4.7124             | 0.3927                       | 2.5465                                 | 1.544                   | 18.53                            | 0.0107                      | 0.080              | 93                                  |
|               | 1.370         | 16        | 0.065    |                    |                              |  | 1.474                   | 17.69                            | 0.0102                      | 0.076              | 98                                  |
|               | 1.334         | 14        | 0.083    |                    |                              |  | 1.398                   | 16.78                            | 0.0097                      | 0.073              | 103                                 |
|               | 1.310         | 13        | 0.095    |                    |                              |  | 1.343                   | 16.12                            | 0.0093                      | 0.070              | 107                                 |
|               | 1.282         | 12        | 0.109    |                    |                              |  | 1.292                   | 15.50                            | 0.0090                      | 0.067              | 111                                 |
| 1 3/4         | 1.620         | 16        | 0.065    | 5.4978             | 0.4581                       | 2.1827                                 | 2.061                   | 24.73                            | 0.0143                      | 0.107              | 70                                  |
|               | 1.584         | 14        | 0.083    |                    |                              |  | 1.971                   | 23.65                            | 0.0137                      | 0.102              | 73                                  |
|               | 1.560         | 13        | 0.095    |                    |                              |  | 1.911                   | 22.94                            | 0.0133                      | 0.099              | 75                                  |
|               | 1.532         | 12        | 0.109    |                    |                              |  | 1.843                   | 22.12                            | 0.0128                      | 0.096              | 78                                  |
|               | 1.490         | 11        | 0.120    |                    |                              |  | 1.744                   | 20.92                            | 0.0121                      | 0.090              | 83                                  |
| 2             | 1.870         | 16        | 0.065    | 6.2832             | 0.5236                       | 1.9099                                 | 2.746                   | 32.96                            | 0.0191                      | 0.143              | 52                                  |
|               | 1.834         | 14        | 0.083    |                    |                              |  | 2.642                   | 31.70                            | 0.0183                      | 0.137              | 55                                  |
|               | 1.810         | 13        | 0.095    |                    |                              |  | 2.573                   | 30.88                            | 0.0179                      | 0.134              | 56                                  |
|               | 1.782         | 12        | 0.109    |                    |                              |  | 2.489                   | 29.87                            | 0.0173                      | 0.129              | 58                                  |
|               | 1.760         | 11        | 0.120    |                    |                              |  | 2.433                   | 29.20                            | 0.0169                      | 0.126              | 59                                  |

**For more information, visit [therminol.com](http://therminol.com).**

**EASTMAN**

**Eastman Corporate Headquarters**

P.O. Box 431  
Kingsport, TN 37662-5280 U.S.A.

U.S.A. and Canada, 800-EASTMAN (800-327-8626)  
Other locations, +(1) 423-229-2000

[eastman.com/locations](http://eastman.com/locations)

Although the information and recommendations set forth herein are presented in good faith, Eastman Chemical Company ("Eastman") and its subsidiaries make no representations or warranties as to the completeness or accuracy thereof. You must make your own determination of its suitability and completeness for your own use, for the protection of the environment, and for the health and safety of your employees and purchasers of your products. Nothing contained herein is to be construed as a recommendation to use any product, process, equipment, or formulation in conflict with any patent, and we make no representations or warranties, express or implied, that the use thereof will not infringe any patent. NO REPRESENTATIONS OR WARRANTIES, EITHER EXPRESS OR IMPLIED, OF MERCHANTABILITY, FITNESS FOR A PARTICULAR PURPOSE, OR OF ANY OTHER NATURE ARE MADE HEREUNDER WITH RESPECT TO INFORMATION OR THE PRODUCT TO WHICH INFORMATION REFERS AND NOTHING HEREIN WAIVES ANY OF THE SELLER'S CONDITIONS OF SALE.

Safety Data Sheets providing safety precautions that should be observed when handling and storing our products are available online or by request. You should obtain and review available material safety information before handling our products. If any materials mentioned are not our products, appropriate industrial hygiene and other safety precautions recommended by their manufacturers should be observed.

© 2026 Eastman. Eastman brands referenced herein are trademarks of Eastman or one of its subsidiaries or are being used under license. Non-Eastman brands referenced herein are trademarks of their respective owners.